

POINT **1600**

User's Guide

Manuel d' Utilisation

Benutzerhandbuch

Manual de Usuario

Manuale Utente

FUJITSU

Fujitsu Personal Systems, Inc. has made every effort to ensure the accuracy and completeness of this document; however, because ongoing development efforts are made to continually improve the capabilities of our products, we cannot guarantee the accuracy of the contents of this document. We disclaim liability for errors, omissions, or future changes herein.

Point 1600 and Point 510 are trademarks of Fujitsu Personal Systems, Inc.

IBM, IBM PC AT, and IBM PS/2 are registered trademarks of IBM Corporation.

MS, MS-DOS, and Microsoft are registered trademarks of Microsoft Corporation. Windows for Workgroups, Windows 95, Windows 98 and Windows for Pen Computing are trademarks of Microsoft Corporation.

PCMCIA is a trademark of the Personal Computer Memory Card International Association.

All other products are trademarks or registered trademarks of their respective companies.

Copyright 1998
Fujitsu Personal Systems, Inc.

No part of this publication may be copied, reproduced, or translated, without the prior written consent of Fujitsu Personal Systems, Inc. No part of this publication may be stored or transmitted in any electronic form without the prior consent of Fujitsu Personal Systems, Inc.

Agency Compliance

UL Notices

Cautions

- For continued protection against the risk of fire, replace only with the same type and rating of fuse.
- There is a danger of explosion if the CMOS battery is incorrectly replaced. Replace only with the same or equivalent type recommended by the manufacturer. Dispose of used batteries according to manufacturer's instruction.
- Changes or modifications not expressly approved by Fujitsu Personal Systems, Inc. could void this user's authority to operate the equipment.

Warnings

- The CMOS battery may explode if mistreated. Do not recharge, disassemble, or dispose of in fire.
- For a spare Point 1600 battery pack, order only Fujitsu Model FMW27BP1.
- To charge the Point 1600 battery pack externally, use only the Fujitsu FMW26BC1 external battery charger.

FCC Notices



DECLARATION OF CONFORMITY according to FCC Part 15

Responsible Party Name: **Fujitsu Personal Systems, Inc.**
Address: **5200 Patrick Henry Drive
Santa Clara, CA**
Telephone: **408-982-9500**

Declares that product: **Model: Point 1600 Pen Tablet
Complies with Part 15 of the FCC Rules**

This device complies with Part 15 of the FCC rules. Operation is subject to the following two conditions: (1) This device may not cause harmful interference, and (2) This device must accept any interference received, including interference that may cause undesired operation.

David Woo - Mgr. Agency Compliance 8-14-98
Full Name / Title Date

Note: *For more detailed information about the FCC rules and their applicability to the Point 1600 pen tablet, refer to Appendix A of this document.*

Table of Contents

Chapter 1

Getting Started

Features and Controls	1-3
Status LEDs	1-4
Included with the Point 1600 Pen Tablet.....	1-6
Optional Accessories	1-7
Connectivity Peripherals	1-8

Chapter 2

Using the Point 1600 Pen Tablet

System Power States	2-1
Low Battery Pack Conditions.....	2-3
Suspend/Resume Button Configuration.....	2-4
Starting or Resuming the System	2-5
Suspending the System	2-6
Other Suspend/Resume Issues.....	2-7
Shutting Down the System	2-8
Using the Pen.....	2-8
Ensuring Pen Accuracy	2-10
Using Hotpads.....	2-10
Charging the Battery Pack (While Installed in the Pen Tablet).....	2-11
Removing and Installing the Battery Pack.....	2-12
Conserving Battery Power.....	2-13
Using Connectors and Peripheral Interfaces	2-14
Optional Wireless LAN Adapter.....	2-17
Using the Optional Built-In Modem	2-17

Chapter 3

Care, Maintenance, and Troubleshooting

Protecting the Display Screen	3-1
Installing a Screen Protector	3-1
Taking Care of the Pen	3-3
Protecting the Pen Tablet in Harsh Environments	3-3
Avoiding Overheating	3-3
Storing the Pen Tablet	3-3
Calibrating the Pen	3-4
Troubleshooting	3-5
System Will Not Resume or Turn On	3-5
System Will Not Respond.....	3-6
Display Screen Is Blank or Difficult to Read.....	3-6
Infrared Data Transfer Is Not Working.....	3-7
Wireless LAN Connection Is Lost	3-8
Cursor Is Not Tracking Pen.....	3-8
Audio Volume Is Too Low	3-8

Appendix A

Agency Notices

FCC Notices	A-1
DOC (Industry Canada) Compliance Notices	A-3

Chapter 1

Getting Started

This chapter gives an overview of the Point 1600 pen tablet's features and explains basic use. The Point 1600™ pen tablet runs the Windows 95 or Windows 98 operating system. Figure 1-1 and Figure 1-2 show the location of features and controls on the pen tablet.

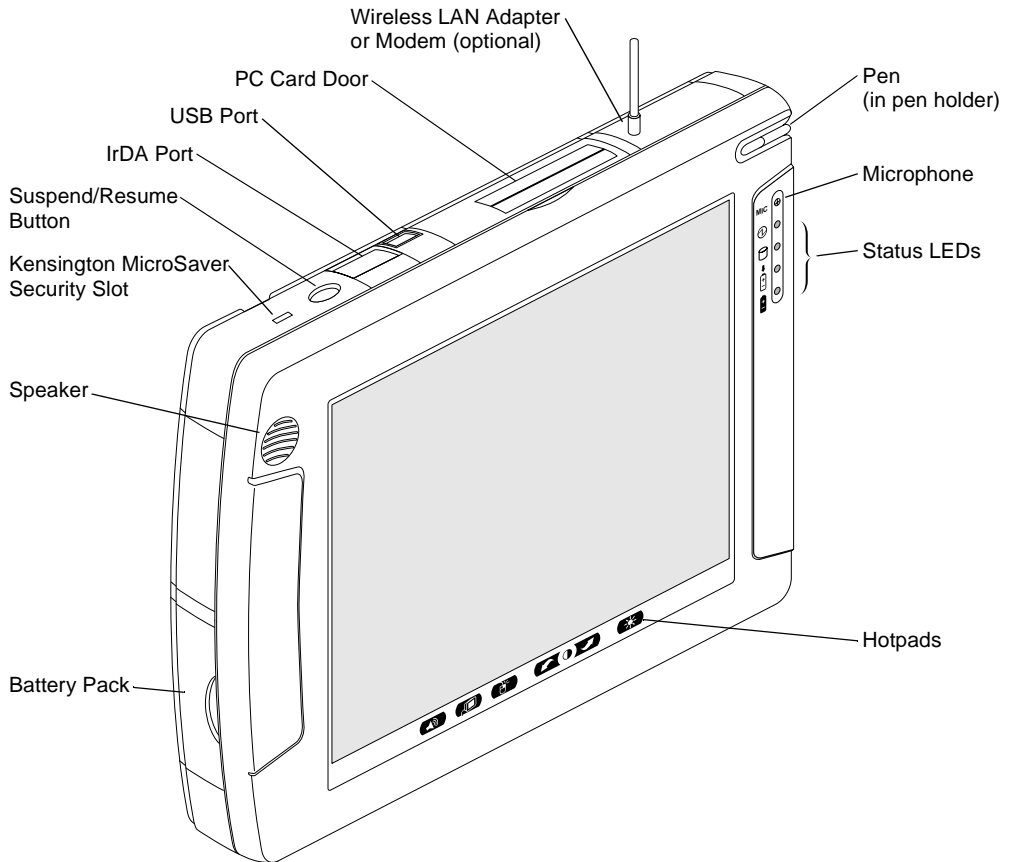

Figure 1-1 Point 1600 Pen Tablet Features – Front

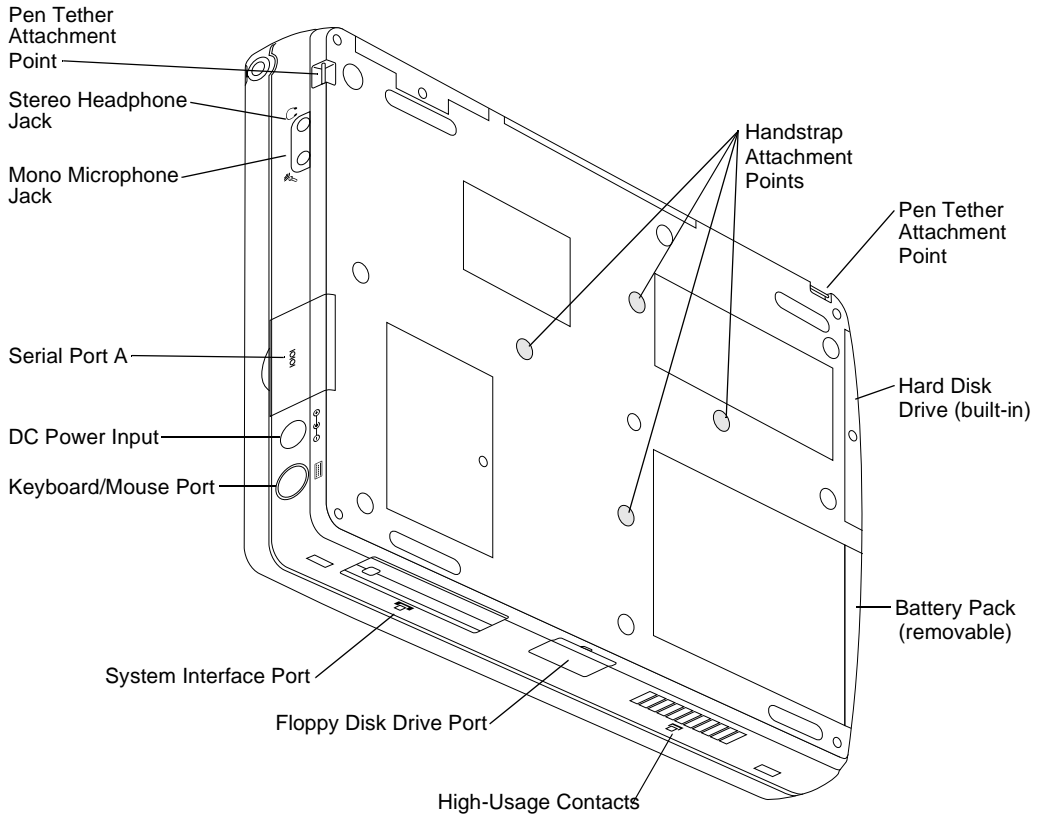

Figure 1-2 Point 1600 Pen Tablet Features – Back

Features and Controls

The main features and controls that you use to operate the Point 1600 pen tablet are described briefly below. Use of these features and controls is described in detail later in this manual. (Features called out in Figure 1-1 and Figure 1-2 which are not listed here are also described later in this manual.)

- **Suspend/Resume Button**
Allows you to suspend or resume system operation or turn the pen tablet on or off depending on how your system is configured.
- **Status LEDs**
Indicate system power state, battery state, and hard disk drive access.
- **Pen and Pen Holder**
The pen is the main input device that you use to enter data and run programs. The pen should be stored in the pen holder while not in use.
- **Hotpads**
Tap on the hotpads to adjust speaker volume, display contrast and brightness, to perform a right-mouse-button click, or select the display device.
- **DC Power Input**
Allows you to attach an external power source to power the pen tablet and charge the battery pack.
- **Keyboard/Mouse Port**
Allows you to connect the Fujitsu keyboard or a PS/2-style mouse. (Most PS/2-style keyboards can be connected successfully.)
- **Optional Wireless LAN Adapter or Built-In Modem**
Your system may be equipped with an optional wireless LAN adapter, in which case the antenna (shown) may be present, or an optional built-in modem, in which case an RJ-11 jack (not shown) is present in this location.
- **Battery Pack**
The battery pack on the Point 1600 pen tablet can be charged in the pen tablet or can be removed from the pen tablet and charged in an external battery charger (sold separately).
- **Hard Disk Drive**
The Point 1600 pen tablet is equipped with a built-in hard disk drive.

Status LEDs

The status LEDs indicate various system conditions including power state, hard disk drive use, and battery charge level. Figure 1-3 shows the status LEDs on the front of the Point 1600 pen tablet.

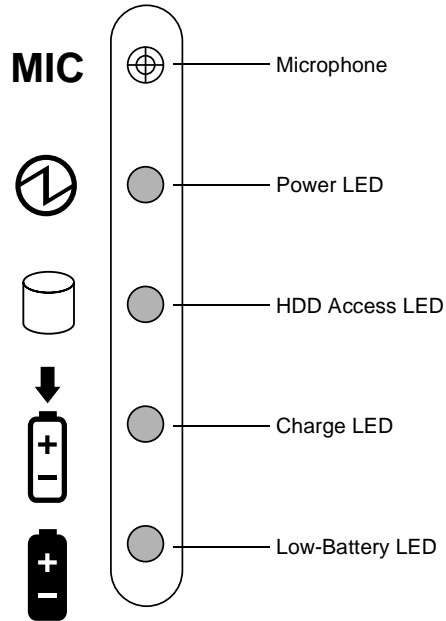





Figure 1-3 Status LEDs

Table 1-1 describes conditions indicated by each status LED. For details on power states indicated by the Power LED, see “System Power States” on page 2-1. For more information about battery use and maintenance, see “Charging the Battery Pack (While Installed in the Pen Tablet)” on page 2-11 and “Low Battery Pack Conditions” on page 2-3.

Table 1-1 Status LEDs

LED	Appearance of LED	System Status
Power LED 	Indicates system power state.	
	LED on continuously.	System is Fully On.
	LED flashing (once every 4 seconds).	Suspend mode.
	LED off	System is off.
HDD Access LED 	Indicates when the system is accessing the built-in hard disk drive (HDD).	
	LED on.	HDD is being accessed.
	LED off.	HDD is not being accessed.
Charge LED 	Indicates battery pack is charging. (Note that this LED flashes once when external power is initially connected.)	
	LED on continuously.	Fast Charge mode, 0 to 89% of capacity.
	LED flashing. (Flashes faster at 90% capacity, slower at 99%.)	Slow Charge mode, 90-99% of capacity.
	LED off.	Not Charging, external power is not connected.
Low-Battery LED 	Indicates low charge condition of the battery pack. See “Low Battery Pack Conditions” on page 2-3 for more information.	
	LED off.	Good Battery, or external power connected.
	LED flashing slowly (1 second on, 1 second off).	Low Battery, approximately 15% charge remaining.
	LED flashing quickly (1/2 second on, 1/2 second off).	Very Low Battery, approximately 8% charge remaining.
	LED flashing very slowly (once every 4 seconds).	Critically Low Battery, system forced to suspend and cannot be resumed unless external power is connected or charged battery pack is installed.

Included with the Point 1600 Pen Tablet

The following items are included with the Point 1600 pen tablet:

- AC adapter
- Optional built-in 56 Kbps* internal modem (V.90): 53 Kbps receive/33.6 Kbps send/14.4 Kbps fax
- Optional built-in wireless LAN adapter*
- Point 1600 pen
- Two screen protectors
- Point 1600 battery pack, installed in the pen tablet
- User's guide for the operating system preinstalled on the pen tablet, with a certificate of authenticity for operating the system software
- Warranty card

* The 56 Kbps rate is nominal; due to FCC restrictions, actual rates are limited to 53 Kbps. (The pen tablet can be equipped with the optional built-in modem or optional built-in wireless LAN adapter, but not both.)

Optional Accessories

The following optional accessories can be used with the Point 1600 pen tablet:

- FMWSP7 Spare Screen Protectors (12-pack)
- FMW27PN1 Spare Pens (5-pack)
- FMWCC28 Slip Case
- FMWCC31 Harsh Environment Case
- FMWST2 Pen Tether
- FMWHS5 Hand Strap
- FMWCB2 Auto Adapter
- FMWBCR1 Bar Code Reader
- FMWCC24 Keyboard Combo Case
- FMWKB3A Mobile Keyboard (US English)
- FMWKB3B Mobile Keyboard (UK English)
- FMWKB3F Mobile Keyboard (French)
- FMWKB3D Mobile Keyboard (German)
- FMWKB3E Mobile Keyboard (Italian)
- FMWFD2 Floppy Disk Drive
- FMWDS3 Folding Desk Stand
- FMW27BP1 Spare Point 1600 Battery Pack
- FMW26BC1 External Battery Charger

Refer to the instructions provided with these accessories for details on their use.

Connectivity Peripherals

The following connectivity peripherals can be used with the Point 1600 pen tablet. Note that the Point 1600 pen tablet is compatible with connectivity peripherals designed for use with the Point 510 pen tablet.

- High-Usage Cradle
- High-Connectivity Cradle
- Port Replicator
- Wall-Mount Cradle
- Portable Port Expander
- Charge-Only Cradle

The nonlocking versions of these peripherals are not equipped with the tubular lock and cradle latches that are present on the locking versions.

Chapter 2

Using the Point 1600 Pen Tablet

This chapter covers the fundamental concepts and system operations with which you need to be familiar to use the Point 1600 pen tablet including:

- Starting the pen tablet
- Using the pen
- Charging the battery pack
- Connecting to other equipment
- Shutting down the pen tablet
- Using hotpads

System Power States

Before you begin using the Point 1600 pen tablet, familiarize yourself with the different system power states that the pen tablet can use. Being familiar with these system states will help you determine whether it is appropriate to turn on, resume, suspend, or shut down the system when you begin a new session or end your current session. System behavior for each system power state (or mode) is described briefly in the following, with each system state listed in decreasing order of power usage:

- **Fully On state**
The system is running and the display screen is on. The system responds to the pen or other input.
- **Idle and Standby state**
Some system functions are regulated or turned off to conserve power. The display screen may be turned off (depending on how your system is configured). The system returns to the Fully On state when pen activity or other input is detected.
- **Suspend mode**
System operation is suspended. Most system functions are turned off to conserve power. Power to memory remains on, maintaining active data including files and programs that were open or running before system operation was suspended. The system does not respond to the pen.
- **Off state**
All system functions are turned off to conserve power. The system does not respond to the pen or other input.

Your system may be configured to transition between these states automatically after a period of inactivity to conserve battery power.

To determine the current system state, observe the Power LED. Table 1-1 on page 1-5 gives the different system states represented by the Power LED. (Note that if the Power LED is off, the Off state is indicated.)

Low Battery Pack Conditions

Table 2-1 gives details on system conditions for each charge level indicated by the Low-Battery LED.

Table 2-1 Low Battery Pack Conditions

Low-Battery LED	Low Battery Condition
LED off.	Good Battery Greater than 15% battery pack charge remaining.*
LED flashing slowly (1 second on, 1 second off).	Low Battery Warning 15% to 8% battery pack charge remaining.*
LED flashing quickly (1/2 second on, 1/2 second off).	Very Low Battery Warning 8% or less battery pack charge remaining.*
LED flashing very slowly (1 short flash every 4 seconds).	<p>Critically Low Battery</p> <ul style="list-style-type: none"> • If the system is running when the charge drops to the Critically Low Battery level, the system is forced into Suspend mode. • If the system is in Suspend mode when the charge drops to the Critically Low Battery level, the system remains in Suspend mode. <p>The system cannot be started or resumed until a charged battery pack is installed or external power is connected.</p>
LED off, system not running and will not start.	<p>Discharged Battery</p> <p>The battery pack charge is not sufficient to provide power in any mode. After the battery pack drops to the discharged level, power is supplied to the system by the built-in bridge battery. The bridge battery can power the system in Suspend mode for about 3 minutes, after which time any data stored in memory (suspended data) is lost.</p> <p>The system cannot be started or resumed until a charged battery pack is installed or external power is connected.</p>

* These are approximate values. The percent of charge remaining indicated by your operating system or power management software may differ.

Suspend/Resume Button Configuration

The Suspend/Resume button on the pen tablet can be configured using one of the following three settings:

- **Normal**

In the Normal setting, the system suspends or resumes operation when you press the Suspend/Resume button. If the system has been shut down, pressing the Suspend/Resume button starts the system.

- **Resume Only**

In the Resume Only setting, the Suspend/Resume button can only be used to resume system operation or start the system if it has been shut down.

- **Power On/Off**

In the Power On/Off setting, the system turns on or off when you press the Suspend/Resume button. (Note that in this setting, pressing the Suspend/Resume button will resume the system if it has been suspended using a software command.)

Caution

If your system is configured to use the Power On/Off setting, **do not** attempt to suspend system operation by pressing the Suspend/Resume button. Doing so will cause data in open files and applications to be lost. Ask your local help desk or reseller for assistance if you are not sure how your system is configured.

Starting or Resuming the System

To start or resume the system,

1. Press the Suspend/Resume button once.

If system operation was suspended in the previous session, system operation will resume. If the system was shut down in the previous session, the system will start and the operating system will load.

2. Wait for the system to start or resume.

It may take several seconds for the system to start or resume after pressing the Suspend/Resume button. (The display screen turns on before the pen becomes active.) **Do not press the Suspend/Resume button repeatedly, more firmly, or hold it down continuously.** Doing so will interrupt the resume or system boot procedure.

You can use the pen tablet as soon as system operation resumes or the operating system has finished loading.

Suspending the System

You can conserve battery power by suspending the system when you are not using the pen tablet. Suspending the system allows you to stop the system without closing files or exiting programs that are open or running.

To suspend the system,

1. Choose one of the following:

- If the Suspend/Resume button on your system is configured to use the Normal setting, press the Suspend/Resume button or carry out the Suspend command in your operating system or application software.
- If the Suspend/Resume button on your system is configured to use the Power On/Off or Resume Only setting, carry out the Suspend command in your operating system or application software.

If you are not sure how the Suspend/Resume button is configured, contact your local help desk for assistance.

2. Wait for the system to suspend operation; it may take a few seconds. The pen tablet emits a double beep (if the speaker is on) just before entering Suspend mode.

Do not press the Suspend/Resume button repeatedly, more firmly, or hold it down continuously. Doing so will interrupt the suspend procedure.

3. Observe the Power LED. If the LED is blinking once every 4 seconds, the system is in Suspend mode.

Once system operation is suspended, you can:

- Remove the battery pack from the pen tablet and install a charged battery pack. (The bridge battery in the pen tablet will provide sufficient power in Suspend mode for about 3 minutes.) To prevent losing unsaved data, wait until system operation is suspended before you remove the battery pack.
- Connect or disconnect peripherals from the pen tablet.
- Resume system operation by pressing the Suspend/Resume button as described earlier.

Other Suspend/Resume Issues

Other issues you should consider when suspending or resuming system operation include the following:

- Your system may be configured to suspend operation automatically after a period of inactivity. Also, your system can be configured to resume operation automatically at a given time or when the optional modem detects a ring on the phone line.
- The system uses a small amount of battery power when in Suspend mode. Eventually, the battery will become fully discharged. (A fully charged battery pack can power the system in Suspend mode for about 10 days.) If you will not be using the system for an extended period of time, shut down the system rather than using Suspend mode.
- If the battery pack charge drops to the Low-Battery Warning level while the system is in Suspend mode, the system will beep periodically (regardless of the speaker volume setting). If this occurs, either resume system operation and shut down the system or attach an external power source, such as the AC adapter, to the pen tablet.
- If the system is running (or in Suspend mode) when the battery pack charge drops to the Critically Low level, the system is forced into Suspend mode and cannot be resumed until external power is connected or a charged battery pack is installed. If this occurs, install a charged battery pack or connect an external power source such as the AC adapter.
- Suspending system operation interrupts data communications; however, some programs may block the system from suspending to prevent an interruption.
- The Suspend/Resume button on your system may be disabled. If this is the case, pressing the Suspend/Resume button will not suspend system operation as described here.
- If your system is equipped with a wireless LAN adapter, you may be logged off the network after a period of inactivity while system operation is suspended. Contact your network administrator or local help desk for details on log-off parameters for your network.
- Your system may be configured to resume when activity is detected on the serial port or when a ring is detected on the modem line.

Shutting Down the System

When you shut down your system, the pen tablet enters the Off power state. If you will not be using the pen tablet for an extended period of time (several days), you should shut down the system to prevent the battery pack from discharging completely.

To shut down the system,

1. If system operation is suspended, resume system operation.
2. Ensure that all valuable data in open files and applications is saved.
3. Choose Shut Down from the Start menu and carry out the Shut Down command.
4. Wait while Windows shuts down your system. The system turns off automatically.

The system is now in the Off state.

***Note:** If you are storing the system, ensure that a charged battery pack is installed to prevent the bridge battery from becoming discharged. The system continues to draw a very small amount of power while in the Off state. When the battery pack charge drops below a predetermined threshold (lower than the Critically Low threshold), the pen tablet draws power from the bridge battery.*

Using the Pen

You can use the Point 1600 pen (included with the pen tablet) to select items and run programs on the Point 1600 pen tablet much as you would use a mouse on a desktop computer. The pen can be used like a two-button mouse. Programs that support handwriting recognition allow you to write characters directly on the screen with the pen.

Caution

- Ensure that a screen protector is installed on the pen tablet display screen before you use the pen. See “Protecting the Display Screen” on page 3-1 for details.
- The warranty does not cover a screen that is scratched as a result of not using a screen protector.
- Do not use a ballpoint pen or any sharp object on the pen tablet. Doing so can mar or scratch the screen surface.

Here are some hints on how to use the pen like a two-button mouse on a desktop system.

- **To select an object**, tap the pen tip on the object once. This functions like a mouse button click with the left mouse button.
- **To “double-click” an object**, as you would double-click with a mouse, tap twice quickly, or “double-tap,” on the object.
- **To “right-click,”** as you would with a mouse, tap the pen tip on the Right Mouse Hotpad once, then tap on the desired object. (The hotpads are described on page 2-10.)
- **To move the cursor**, lift the pen (the cursor stops moving) and then tap the screen where you want the cursor to appear (the cursor appears in that area).
- **To move or “drag” an object on the screen**, place the pen tip directly over the object, then as you press and hold the pen tip against the display screen, move the pen.

The pen can be attached to the tablet with an optional pen tether. The pen tablet has attachment points on the right and left sides to accommodate left-handed and right-handed users.

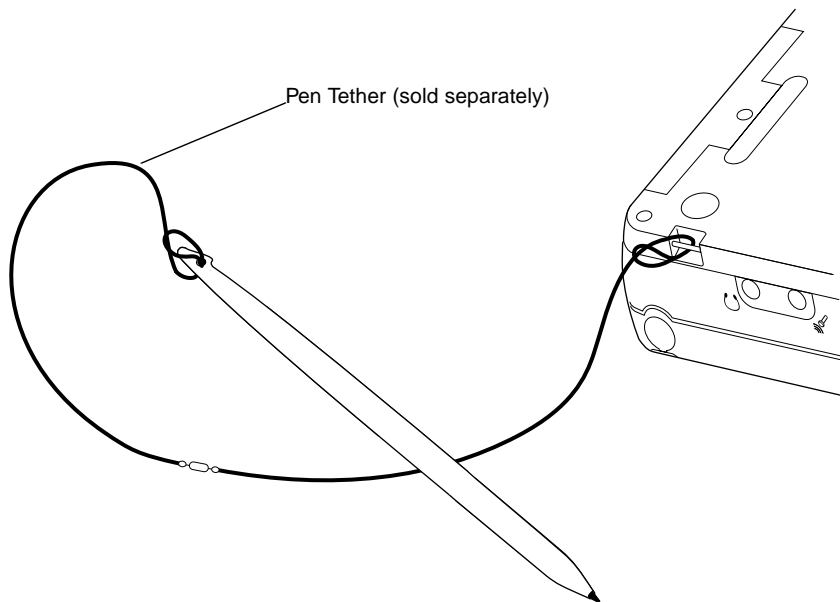

Figure 2-1 Point 1600 Pen and Tether

Ensuring Pen Accuracy

The Point 1600 pen tablet comes from the factory already calibrated so that the cursor location matches the pen tip location. If the cursor is not displayed directly under the pen tip when you touch the screen, then you should calibrate the pen tablet. For more information, see “Calibrating the Pen” on page 3-4.

Using Hotpads

The *hotpads* are controls along the lower edge of the Point 1600 screen that let you use functions and make adjustments to the system. You use the hotpads by tapping them with the pen. The following figure shows the name of each hotpad. Table 2-2 shows the function performed when you tap each hotpad.

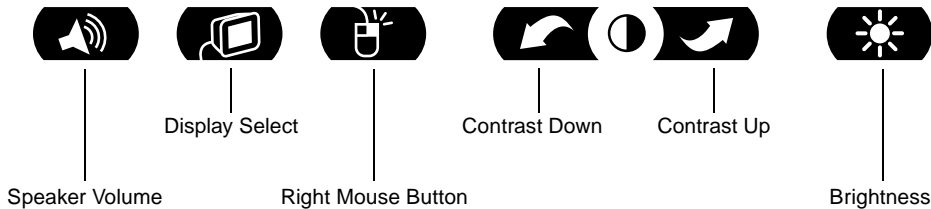







Table 2-2 Hotpads

Speaker Volume		Tap this hotpad to change the speaker volume to the low, medium, high, or off setting. (Note that the sound level may also be controlled by settings in your application or operating system software.)
Display Select		Tap this hotpad to select an external monitor, the pen tablet display screen, or both as the active display.
Right Mouse button		Tap this hotpad once to perform a right mouse button click with your next pen tap.
Contrast Down Contrast Up		Tap these hotpads (or press and hold with the pen tip) to adjust the display screen contrast up or down.
Brightness		Tap this hotpad to change the display brightness setting. The brightness can be set to one of 2 levels (high or low).

Charging the Battery Pack (While Installed in the Pen Tablet)

The Point 1600 battery pack can be charged while it is installed in the Point 1600 pen tablet. To charge the battery pack,

1. Look at the Low-Battery LED while the pen tablet is disconnected from external power to determine the battery pack charge level before you begin charging the battery pack. Table 1-1 on page 1-5 shows the battery pack charge level represented by the Low-Battery LED. The lower the battery level, the longer the battery pack will require for recharging.
2. Connect the pen tablet to an external power source. The Charge LED flashes once when external power is initially connected. The Charge LED will then indicate whether the charge level is above or below 90% as discussed in Table 1-1 on page 1-5. (Note that external power can be provided by a source such as an AC adapter or a connectivity peripheral that provides DC power.)

If the battery pack charge is below 90%, the battery pack charges in fast charge mode. If the battery pack charge is 90% or higher, the battery pack charges in slow charge mode. (This protects the battery pack from being overcharged.)

If fully discharged, the battery pack recharges to 90% in about 90 minutes. (Charging may take longer if peripherals are attached.) You can use the pen tablet, suspend system operation, or shut down the system, without interrupting the charging process. Also, note that there is no “memory effect”. You can begin charging the battery pack at any charge level.

Removing and Installing the Battery Pack

The battery pack can be removed from the pen tablet and replaced with a charged battery pack. You can then charge the battery pack that you removed in the optional external battery charger. You can remove or install the battery pack while the system is Off, in Suspend mode, or connected to external power.

Caution

Do not remove the battery pack while the system is running unless the system is connected to an external power source such as the AC adapter. Doing so will turn off the system and can damage files used by the operating system or applications.

To remove and install the battery pack,

1. Suspend or shut down the pen tablet. (Save any important files and information in programs that you are using before shutting down the pen tablet.) For more information, see “Suspending the System” on page 2-6 or “Shutting Down the System” on page 2-8.

2. Slide the battery latch on the battery pack currently installed in the pen tablet to the open position as shown in Figure 2-2.

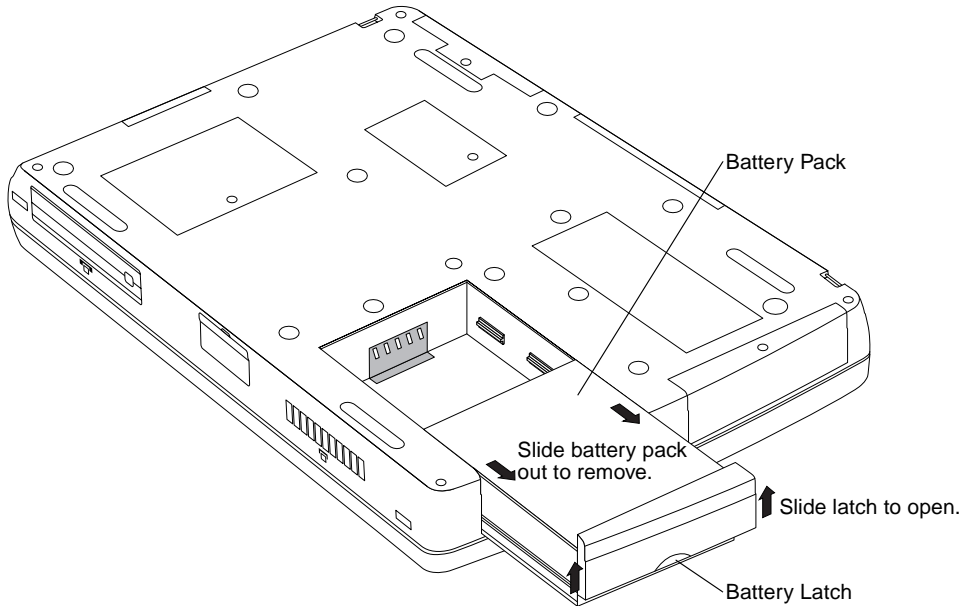

Figure 2-2 Removing the Battery Pack

3. Slide the battery pack out of the pen tablet.

You can now install a charged battery pack in the pen tablet and charge the battery pack that you removed in an external battery charger if one is available. See the instructions that came with your external battery charger for details.

4. To install a battery pack in the pen tablet, slide the latch on the battery pack to the open position.
5. Slide the battery pack into the pen tablet until it fits snugly. Slide the latch to the closed position to latch the battery pack in place.

You can now start or resume the system and use the pen tablet.

Conserving Battery Power

A fully charged battery pack can power the Point 1600 pen tablet for about 4 hours under typical use (with power management). Your results may vary depending on how the pen tablet is configured. You can extend the life of your battery pack by conserving battery power.

Here are some suggestions for conserving battery power:

- If you will not be using the pen tablet for a few minutes, put the pen tablet in Suspend mode (see “Suspending the System” on page 2-6).
- If you will not be using the pen tablet for an extended period of time, such as at the end of your work day, shut down the system.
- Select the low brightness setting for the screen by tapping the Brightness Hotpad (see “Using Hotpads” on page 2-10).

Using Connectors and Peripheral Interfaces

Connectors and peripheral interfaces on the Point 1600 pen tablet allow you to connect a variety of equipment to the pen tablet, such as a microphone, headphones, keyboard, or printer. You can also connect your pen tablet to one of several cradles, which allow you to connect to stationary peripherals easily.

For details on using cradles and other connectivity peripherals, refer to the *Connectivity Peripherals User Guide* or contact your local help desk.

The location of peripheral connectors on the pen tablet are shown in Figure 2-3, Figure 2-4, and Figure 2-5.

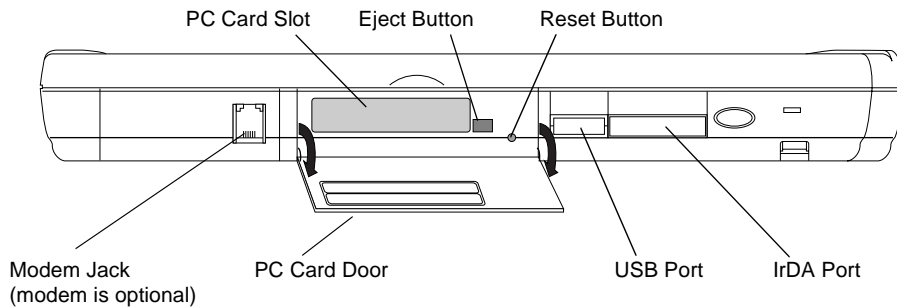

Figure 2-3 Point 1600 Pen Tablet Connectors - Top

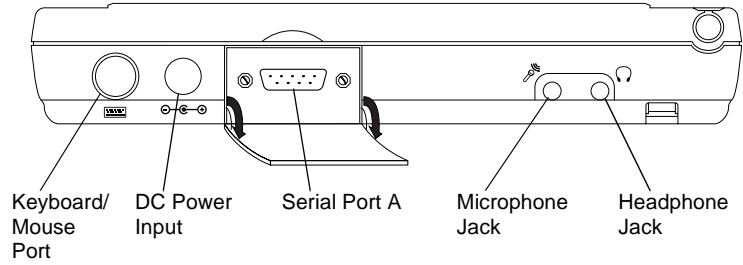

Figure 2-4 Point 1600 Pen Tablet Connectors- Right

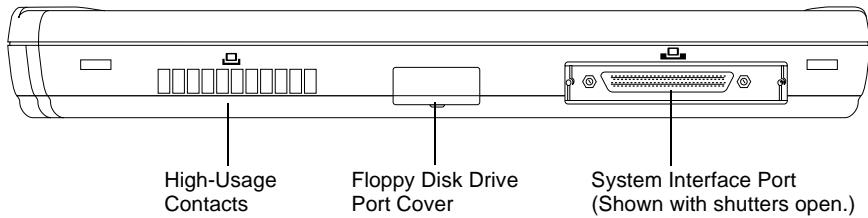

Figure 2-5 Point 1600 Pen Tablet Connectors - Bottom

Peripheral connectors on the pen tablet are described in the following:

- **Modem Jack (optional)**

Systems with an optional built-in modem can connect to a phone line using this jack.

- **PC Card Slot**

This slot allows you to use a PC Card with the Point 1600 pen tablet. To remove a PC Card, press the Eject button inside the PC Card door.

- **Universal Serial Bus (USB) Port**

The USB Port allows you to connect Universal Serial Bus-compliant devices to the pen tablet.

- **IrDA Port**

This port is an infrared transceiver built into the pen tablet which allows you to communicate with other devices that are compliant with the IrDA Standard Revision 1.1 or 1.0. Effective range for infrared communication is about 3 feet, and within 15 degrees off of center. A clear line-of-sight path must exist between the IrDA port on the pen tablet and the IrDA transceiver on the other device.

- **Keyboard/Mouse Port**

This port allows you to connect the Fujitsu keyboard or a PS/2-style mouse. (Most PS/2-style keyboards can be connected successfully.)

- **DC Power Input**

This input allows you to connect an external power source such as the AC adapter or Auto adapter.

- **Serial Port A**

This is a 9-pin RS-232-C serial port which allows you to connect a device with a serial port such as an external modem.

- **Microphone Jack**

This jack allows you to connect a monaural microphone to the pen tablet. The pen tablet's built-in microphone is disabled when you use this jack.

- **Headphone Jack**

This jack allows you to connect stereo headphones or external powered speakers to the pen tablet. The pen tablet's built-in speaker is disabled when you use this jack.

- **High-Usage Contacts**

These metal contacts allow you to use the pen tablet with peripherals such as the high-usage cradle and charge-only cradle.

- **System Interface Port**

This port allows you to use the pen tablet with peripherals such as the portable port expander or high-connectivity cradle.

- **Floppy Disk Drive Port**

This port allows you to connect the Fujitsu FMWFD2 floppy disk drive.

Optional Wireless LAN Adapter

The Point 1600 pen tablet can be equipped with an optional wireless local area network (LAN) adapter that allows you to send and receive data over a wireless network at your work site. To access the wireless network, your pen tablet must be within range of a *wireless hub* or *access point*. Access points can be stationed throughout the facility to carry the signals between the Point 1600 pen tablet and the wired LAN. Contact your local help desk or the administrator for your wireless network for details on using the pen tablet with a wireless LAN.

Using the Optional Built-In Modem

Some systems are equipped with an optional built-in fax/data modem. To use the modem,

1. Connect a phone line to the modem jack on the pen tablet. Figure 2-3 shows the location of the modem jack. (The built-in modem is designed for global use; however, an adapter may be required to connect your phone line to the modem jack in countries outside North America. Obtain an adapter from a local supplier if necessary.)
2. Start your communications software.

You can now use the modem with your communications software. Refer to the documentation for your communications software for details on connecting to a dial-up service.

Note the following when using the modem:

- If your telephone service includes a call-waiting feature, it should be disabled before you use your modem to avoid a communication interruption. Contact your telephone company for instructions on how to disable call waiting.
- If the modem does not appear to be responding, ensure that the modem is enabled and properly configured in your operating system software. Contact your local help desk or dial-up service provider for help configuring modem settings.

Chapter 3

Care, Maintenance, and Troubleshooting

This chapter provides information on routine care and maintenance of the Point 1600 pen tablet. Information on troubleshooting some common problems is also given.

Protecting the Display Screen

The Point 1600 pen tablet is designed to provide you with years of service. Using a screen protector will help ensure that the screen remains as clear as possible. When installed, the screen protector becomes a durable, replaceable, antiglare writing surface that protects the display screen from abrasion.

To obtain additional screen protectors, use order number FMWSP7 (12-pack). Additional information about installation is included with the screen protectors.

Caution

During normal use of the pen tablet, small particles from the environment can become embedded in the pen tip and scratch the screen. To prevent scratching the screen, ensure that a screen protector is installed before using your pen tablet. The warranty does not cover a screen that is scratched as a result of not using a screen protector.

Installing a Screen Protector

To install a new screen protector on your pen tablet:

1. If a screen protector is already installed on the display screen, remove it before installing the new screen protector.

The screen protector is held onto the display screen surface by a thin strip of adhesive around the edges. A notch in one corner of the screen protector allows you to slide your fingernail under the screen protector and easily remove the screen protector.

2. Clean the display screen surface by wiping the screen surface gently using a soft cotton cloth dampened with denatured alcohol. Ensure that all film has been removed from the screen before applying a new screen protector.

Caution

The Point 1600 pen tablet is **not waterproof**. Do not pour liquids on the system or wash it with a heavily soaked cloth.

3. Remove the protective plastic cover from the adhesive side of the screen protector first.
4. Apply the screen protector to the display screen surface. When doing so, orient the screen protector with the adhesive side of the screen protector facing the display screen and the notched corner of the screen protector toward the lower left corner of the display screen.
5. Remove the protective plastic cover from the face of the screen protector. (The screen protector is shipped with protective plastic covers on both sides.)
6. **Apply pressure to the screen protector along the edges.** The adhesive sets completely within 48 hours. To ensure a good seal between the screen protector and the display, do not lift the screen protector from the display once it has been applied.
7. Wipe the screen protector with a soft dry cloth to remove any low-tack adhesive; this will help to prevent the pen tip from squeaking.

The screen protector is now installed.

Taking Care of the Pen

The Point 1600 pen tip is made of a soft plastic material that is designed to minimize scratching of the display screen. With use, the pen tip may become worn or may pick up particles of dust or dirt that can scratch the display screen. Using a damaged or warped pen tip on the Point 1600 pen tablet may cause unpredictable results. If your pen exhibits problems, replace the pen with another Point 1600 pen. Replacement pens are available from your reseller (order number FMW27PN1, 5-pack).

Protecting the Pen Tablet in Harsh Environments

The Point 1600 pen tablet is designed for use in protected environments where there is no direct exposure to rain, mists, or sprays. Avoid exposing the pen tablet to these conditions. Note that using the pen tablet in a slip case or harsh environment case offers some protection; however, neither the slip case or harsh environment case renders the pen tablet waterproof or submersible.

Avoiding Overheating

The pen tablet monitors its internal temperature. As the internal temperature approaches the tolerable limits of heat-sensitive components, system functions are automatically limited or turned off to prevent heat damage.

Heat does not dissipate as efficiently when the pen tablet is installed in the harsh environment case. Ensure that the pen tablet is either suspended or off when external power is connected and the pen tablet is in the harsh environment case. This avoids overheating while the battery pack is charging.

Storing the Pen Tablet

Store the pen tablet in the Fully Off state with a charged battery pack installed. The battery pack provides power to some internal components even when the pen tablet is turned off. You can store the pen tablet for about 30 days with a fully charged battery pack installed. After 30 days, you should recharge the battery pack or replace it with a fully charged battery pack.

Calibrating the Pen

If the cursor does not appear under the tip of the pen or appears to be misaligned with the pen tip, you should calibrate the pen. The pen tablet determines where the pen tip touches the display screen in order to determine the correct location of the cursor. Calibrating the pen may be necessary to accurately align the cursor with the actual position of the pen tip in the following situations:

- The previous user of the pen tablet writes with the opposite hand and has calibrated the pen tablet.
- The Point 1600 pen tablet has been in use for some time without being recalibrated.
- The screen has been rotated from landscape (wide) to portrait (tall) orientation, or from portrait to landscape orientation. (Note that rotating the screen does not affect pen calibration, however, changing the screen orientation may cause you to hold the pen tablet and pen in a slightly different position.)

To calibrate the pen:

1. From the Start menu, choose Settings, then choose Control Panel. Double-tap the Pen Configuration icon. Tap the Calibration tab. On the Calibration property sheet, tap the Pen Calibration button. Instructions for calibrating the pen are displayed.

Note that if the pen is too far out of calibration, you cannot perform the pen calibration procedure. In this case, the system prompts you to restore default calibration settings. Tap the Default Calibration button. You can calibrate the pen after default settings are restored.

2. Position the pen tablet as you normally do during use. (Hold the pen at the angle that you regularly use.)

Ensure that you touch only the screen with the tip of the pen during the calibration procedure. Touching your hand or any object other than the pen tip on the screen will cause inaccurate pen calibration.

3. Perform the calibration steps according to the instructions on the screen. The calibration utility displays a cross-hair symbol in each corner of the screen, one corner at a time. Hold the pen as you normally do while using the system and, as accurately as possible, tap the center of each cross-hair as it is displayed.

4. A dialog box is displayed after you tap the last of the cross-hair symbols. Choose one of the following in the dialog box:

- **OK:** If you are satisfied that you tapped the cross-hairs accurately. (Your taps are used to calibrate the screen.)
- **Cancel:** If you do not want to use your taps to calibrate the screen.
- **Recalibrate:** If you want to try again. The calibration instructions reappear. (Go to step 3 of this procedure.)

If you don't choose any of the buttons in the dialog box within 20 seconds, your new calibration settings are discarded and previous calibration settings are used.

If you successfully performed the procedure above, the pen is now calibrated, and you can use the system as you normally would.

Troubleshooting

Solutions to some common problems are described in this section. If you are experiencing a problem with your Point 1600 pen tablet that you cannot solve by taking the actions described here, contact your local help desk.

System Will Not Resume or Turn On

If the system will not resume or turn on, check the following possible causes:

- The battery pack may be discharged to the critically low level or may be defective. When the battery pack cannot supply adequate power, the pen tablet will not resume or start. Connect an external power supply (such as the AC adapter or a cradle that supplies external power), or install a charged battery pack in the pen tablet.
- The pen tablet might be too hot. To avoid damage to heat-sensitive components, the pen tablet enters Suspend mode if it gets too hot. The system cannot resume operation until it cools off to a predetermined temperature. Move the pen tablet to a cooler location and prevent direct sunlight from shining on it.

System Will Not Respond

If the system will not respond to user input or appears to be “hung”, you can turn off the system by pressing the Reset button. You can then start the system by pressing the Suspend/Resume button. The location of the Reset button is shown on page 2-14.

Caution

Active data will be lost if you press the Reset button. If your system hangs frequently, there may be problems with your operating system configuration or pen tablet hardware. Contact your local help desk for further assistance if necessary.

Display Screen Is Blank or Difficult to Read

If the display screen is blank or difficult to read, try adjusting the display screen settings. See “Using Hotpads” on page 2-10 for details on adjusting the display screen settings. Also, check the following:

- If the display screen is blank, confirm that the pen tablet is running (the Power LED is on continuously).
- The display contrast setting may be set to extreme high or low levels, causing the screen to appear blank. Try adjusting the contrast using the hotpads.
- The ambient temperature can affect the display contrast. You may need to adjust the display contrast periodically, using the hotpads, to compensate for changes in temperature.
- The pen tablet might be set up to use an external monitor. Tap the Display Select Hotpad to determine if the pen tablet display screen is selected.
- The video timeout may have expired. To conserve power, the system may be configured to turn off the display screen after a period of time. Tap the screen to activate the display.

Infrared Data Transfer Is Not Working

If you are experiencing problems transferring data over the pen tablet's infrared interface (IrDA port), check the following:

- Can the IrDA port on the pen tablet “see” the IrDA port on the other device? There must be a direct line-of-sight path between the IrDA port on the Point 1600 pen tablet and the IrDA port on the other device.
- Ensure that you are pointing the IrDA port on the pen tablet at the port on the other device. The “viewing angle” from the IrDA port on the pen tablet must not be more than 15 degrees from center.
- Ensure that the pen tablet is close enough to the other device. The distance between the two devices must be no more than approximately 3 feet (1 meter).
- The device that you are trying to communicate with must be compliant with the IrDA Standard Revision 1.1 or lower. If you are unsure, contact your local help desk.
- Your system must be properly configured before the IrDA port can be used. Contact your local help desk for assistance if necessary.

Wireless LAN Connection Is Lost

The wireless LAN adapter in the pen tablet is designed to send and receive signals reliably under most conditions. Occasionally, the signal is interrupted. This could happen when the Point 1600 pen tablet is too far from an access point, or the signal is physically obstructed by factors such as the material in the structure of the building.

If the pen tablet pauses transmission and does not appear to be resuming transmission, try moving the pen tablet away from the immediate area until the signal resumes. If moving the pen tablet does not solve the transmission problem, or if this problem typically occurs in a specific location, contact your local help desk or reseller.

Cursor Is Not Tracking Pen

If the cursor on the screen is not accurately tracking the pen or appears to be misaligned with the pen, calibrate the pen. See “Calibrating the Pen” earlier in this chapter for details.

Audio Volume Is Too Low

If the audio volume on your pen tablet speaker or external headphones is too low, check the following:

- Ensure that the volume level, set with the Speaker Volume Hotpad, is set to an audible level.
- Ensure that any volume control in your audio software is set to an audible level.
- The audio volume control in your operating system may be muted.

Appendix A

Agency Notices

FCC Notices

This equipment has been tested and found to comply with the limits for a Class B digital device, pursuant to Part 15 of the FCC rules. Changes or modifications not expressly approved by Fujitsu Personal Systems, Inc., could void the user's authority to operate the equipment.

Notice to Users of Radios and Television

These limits are designed to provide reasonable protection against harmful interference in a residential installation. This equipment generates, uses, and can radiate radio frequency energy and, if not installed and used in accordance with the instructions, may cause harmful interference to radio communications. However, there is no guarantee that interference will not occur in a particular installation. If the equipment does cause harmful interference to radio or television reception, which can be determined by turning the equipment off and on, the user is encouraged to try to correct the interference by one or more of the following measures:

- Reorient or relocate the receiving antenna.
- Increase the separation between the equipment and receiver.
- Connect the equipment into an outlet that is on a different circuit than the receiver.
- Consult the dealer or an experienced radio/TV technician for help.

Shielded interconnect cables must be employed with this equipment to ensure compliance with the pertinent RF emissions limits governing this device.

Notice to Users of the US Telephone Network

Note: *Some configurations of the Point 1600 pen tablet do not have an internal modem. The following information applies only to those systems with an internal modem.*

The Point 1600 pen tablet is supplied with an internal modem which complies with Part 68 of the FCC rules. On the pen tablet is a label that contains the FCC Registration Number and Ringer Equivalence Number (REN) of this system, along

with other information. If requested, users must provide their telephone company with the following information:

- The telephone number to which the pen tablet is connected
- The Ringer Equivalence Number (REN) for this equipment
- The information that the system requires a standard modular jack type USOC RJ-11C which is FCC Part 68-compliant
- The FCC Registration Number

This equipment is designed to be connected to the telephone network or premises wiring using a standard modular jack type USOC RJ-11C which is FCC Part 68-compliant.

The REN is used to determine the number of devices you may connect to your telephone line and still have all those devices ring when your number is called. Too many devices on one line may result in failure to ring in response to an incoming call. In most, but not all, areas, the sum of all of the devices should not exceed five (5). To be certain of the number of devices you may connect to your line, as determined by the RENs, contact your local telephone company.

If this equipment causes harm to the telephone network, your telephone company may discontinue your service temporarily. If possible, they will notify you in advance. If advance notice is not practical, they will notify you as soon as possible. You will also be advised of your right to file a complaint with the FCC.

This fax modem also complies with fax branding requirements per FCC Part 68.

If you experience trouble with this equipment, please contact your support representative.

Your telephone company will probably ask you to disconnect this equipment from the telephone network until the problem is corrected and you are sure that the equipment is not malfunctioning.

This equipment may not be used on coin service telephones provided by your telephone company. Connection to party lines is subject to state tariffs. Contact your state's public utility commission, public services commission, or corporation commission for more information.

FCC rules prohibit the use of non-hearing aid compatible telephones in the following locations or applications:

- All public or semipublic coin-operated or credit card telephones.
- Elevators, highways, tunnels, (automobile, subway, railroad, or pedestrian) where a person with impaired hearing might be isolated in an emergency.
- Places where telephones are specifically installed to alert emergency authorities such as fire, police, or medical assistance personnel.
- Hospital rooms, residential health care facilities, convalescent homes, and prisons.
- Workstations for the hearing impaired.
- Hotel, motel, or apartment lobbies.
- Stores where telephones are used by patrons to order merchandise.
- Public transportation terminals where telephones are used to call taxis or to reserve lodging or rental cars.
- In hotel and motel rooms at least ten percent of the rooms must contain hearing aid compatible telephones which will be provided to hearing impaired customers on request.

DOC (Industry Canada) Compliance Notices

This digital apparatus does not exceed the Class B limits for radio noise emissions from digital apparatus as set forth in the radio interference regulations of the Canadian Department of Communications.

Le présent appareil numérique n'émet pas de bruits radioélectriques dépassant les limites applicables aux appareils numériques de classe B prescrites dans le règlement sur le brouillage radioélectrique édicté par le Ministère des Communications du Canada.

Notice to Users of Radios and Television

This Class B digital apparatus meets all requirements of the Canadian Interference-Causing Equipment regulations.

Cet appareil numérique de la classe B respecte toutes les exigences du règlement sur le matériel brouilleur du Canada.

Notice to Users of the Canadian Telephone Network

The Canadian Industry Canada label identifies certified equipment. This certification means that the equipment meets certain telecommunications network protective, operational, and safety requirements. The Department does not guarantee the equipment will operate to the user's satisfaction.

Repairs to telecommunication equipment should be made by a Canadian authorized maintenance facility. Any repairs or alterations not expressly approved by Fujitsu Personal Systems, Inc. or any equipment failures may give the telecommunications company cause to request the user to disconnect the equipment from the telephone line.

The connecting arrangement code for this equipment is CA11A.

The Load Number is 0.2.

The Load Number assigned to each telephone terminal device denotes the percentage of the total load to be connected to a telephone loop or circuit to be used by the device to prevent overloading. The termination on a loop may consist of any combination of devices such that the total of the load numbers of all devices does not exceed 100.

Caution

For safety, users should ensure that the electrical ground of the power utility, the telephone lines, and the metallic water pipes are connected together. Users should **not** attempt to make such connections themselves but should contact the appropriate electric inspection authority or electrician. This may be particularly important in rural areas.

Avis Aux Utilisateurs Du Réseau Téléphonique Canadien

L'étiquette canadienne Industrie Canada identifie l'équipement certifié. Cette certification signifie que l'équipement satisfait certaines normes de protection, d'exploitation et de sécurité des réseaux de télécommunications. Le département ne garantit pas le fonctionnement de l'équipement à la satisfaction de l'utilisateur.

Le Point 1600 possède un modem interne conforme aux normes de certification d'Industrie Canada pour protéger les réseaux de télécommunications et satisfaire aux normes de sécurité. Avant de connecter cet équipement à une ligne téléphonique, l'utilisateur doit vérifier s'il est permis de connecter cet équipement aux installations

de télécommunications locales. L'utilisateur est averti que même la conformité aux normes de certification ne peut dans certains cas empêcher la dégradation du service.

Les réparations de l'équipement de télécommunications doivent être effectuées par un service de maintenance agréé au Canada. Toute réparation ou modification, qui n'est pas expressément approuvée par Fujitsu Personal Systems, Inc., ou toute défaillance de l'équipement peut entraîner la compagnie de télécommunications à exiger que l'utilisateur déconnecte l'équipement de la ligne téléphonique.

Le code d'arrangement de connexion de cet équipement est CA11A.

Le numéro de charge est 0.2.

Le numéro de charge assigné à chaque terminal téléphonique indique le pourcentage de la charge totale pouvant être connecté à une boucle ou à un circuit téléphonique, utilisé par ce périphérique afin de prévenir toute surcharge. La terminaison d'une boucle peut être constituée de n'importe quelle combinaison de périphériques de sorte que le total de numéros de charge de tous les périphériques n'excède pas 100.

Avertissement

Pour assurer la sécurité, les utilisateurs doivent vérifier que la prise de terre du service d'électricité, les lignes téléphoniques et les conduites d'eau métalliques sont connectées ensemble. Les utilisateurs NE doivent PAS tenter d'établir ces connexions eux-mêmes, mais doivent contacter les services d'inspection d'installations électriques appropriés ou un électricien. Ceci peut être particulièrement important en régions rurales.

Index

A

amber LED, see also low-battery LED, 1-5

B

battery pack, 1-3
 battery life, 2-13
 charging, 2-11
 conserving power, 2-13
 critically low level, 1-5, 2-3, 2-7
 discharged battery, 2-3
 low battery conditions, 2-3
 low battery warning, 2-7
 low-battery LED, 2-3
 removing and installing, 2-12
battery power
 used in suspend mode, 2-7
bridge battery, 2-3

C

calibrating the pen, 2-10, 3-4
care and maintenance, 3-1
charge status LED, 1-4–1-5
charging the battery pack in the pen tablet, 2-11
connectivity peripherals, 1-8
connectors and peripheral interfaces, 2-14
cradles, 1-8, 2-15
critically low battery level, 1-5, 2-7
cursor not tracking pen, 3-8

D

DC power input, 1-3, 2-15
display
 blank screen, 3-6
 hotpad, 2-10
 screen contrast, adjusting, 2-10
 screen protector, 1-6, 2-8, 3-1
 screen, protecting, 2-8, 3-1
 selecting, 2-10

E

eject button, PC Card, 2-14

F

FCC rules, A-1
features and controls, 1-3
floppy disk drive port, 2-17
fully on state, 2-1

G

green LED, 1-5

H

handstrap attachment points, 1-2
hard disk drive, 1-3
harsh environments, 3-3
HDD access LED, 1-5
headphones, external jack, 2-15
high-usage contacts, 2-15–2-16
hotpads, 1-3
 contrast, 2-10
 description, 1-3
 display select, 2-10
 right mouse button, 2-9–2-10
 using, 2-10

I

idle and standby states, 2-1
IrDA port
 location, 2-15
 problems with, 3-7

K

Kensington security slot, 1-1
keyboard/mouse port, 1-3, 2-15–2-16

L

- LEDs, about, 1-4
- low battery warning, 2-7
- low battery, recharging, 2-11
- low-battery LED, 1-5, 2-3

M

- metal contacts, 2-16
- microphone
 - external jack, 2-15
- modem, 1-3, 1-6, 2-17

O

- off state, 2-1
- optional accessories, 1-7
- overheating, avoiding, 3-3

P

- PC Card
 - door, 2-14
 - eject button, 2-14
 - slot, 2-14
- pen
 - cursor not tracking, 3-8
 - description, 1-3
 - pen tether, 2-9
 - replacement order number, 3-3
 - tip, 3-3
 - using, 2-8
- pen tablet
 - battery pack, 1-1, 1-3, 2-12
 - calibrating the pen, 2-10, 3-4
 - display screen, protecting, 3-1
 - features and controls, 1-1, 1-3
 - peripheral interfaces, 2-14
 - power, 1-5
 - resuming, 2-5
 - shutting down, 2-8
 - speaker, disabled when using headphone jack, 2-16
 - starting, 2-5
 - storing, 3-3
 - suspending system operation, 2-6

- using the pen tablet, 2-1
- peripheral interfaces, 2-14
- power
 - conserving battery power, 2-13
 - starting or resuming the pen tablet, 2-5
- power LED, 1-5, 2-2
- power usage, 2-1
- problems, solving, 3-5
- protecting the display screen, 3-1

R

- reset button, 2-14, 3-6
- resume, 3-5
- right-click mouse operation, 2-9–2-10

S

- screen protector, 1-6, 2-8, 3-1
- serial port, 2-15
- shutting down the pen tablet, 2-8
- solving problems, 3-5
- speaker volume setting, 2-7, 2-10
- speaker, disabled when using headphone jack, 2-16
- starting or resuming the pen tablet, 2-5
- status LEDs, 1-3–1-5
- suspend mode, 1-5, 2-1, 2-4, 2-6–2-7, 2-14
- suspend/resume button, 1-3, 2-4
- suspend/resume button, disabled, 2-7
- suspend/resume issues, 2-7
- suspending the system, 2-6
- system interface connector, 2-15
- system states, 2-1

T

- troubleshooting, 3-5

W

- wireless LAN adapter, 1-3, 2-17, 3-8